

agenda

November 1, 2018 @ 12 p.m.

City Hall Chapman Room
401 Park Avenue South · Winter Park, Florida

advisory board

1 administrative items

- A. Approval of the meeting minutes from 8-23-18
- B. Discussion with Community Development Director

2 action items

3 informational items

- A. Hannibal Square Streetscape Guidelines
- B. Snow in the Park Special Event

4 new business items

- A. FRA Conference/Denning
- B. Next CRAAB meeting date change (11/22)

5 adjournment items

appeals & assistance

"If a person decides to appeal any decision made by the Commission with respect to any matter considered at such meeting or hearing, he/she will need a record of the proceedings, and that, for such purpose, he/she may need to ensure that a verbatim record of the proceedings is made, which record includes the testimony and evidence upon which the appeal is to be based." (F. S. 286.0105).

"Persons with disabilities needing assistance to participate in any of these proceedings should contact the City Clerk's Office (407-599-3277) at least 48 hours in advance of the meeting."

winter park

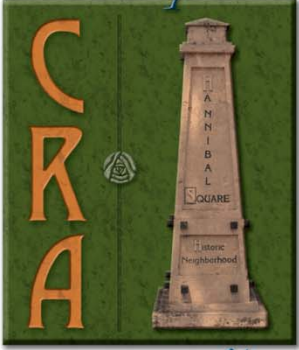

community
redevelopment
agency

agenda item

meeting date	November 1, 2018	approved by <input type="checkbox"/> City Manager <input type="checkbox"/> City Attorney <input checked="" type="checkbox"/> N/A
item type	<input checked="" type="checkbox"/> Administrative <input type="checkbox"/> Action <input type="checkbox"/> Information	

advisory board

Subject

Approval of Minutes

motion | recommendation

Motion to approve the August 23, 2018 meeting minutes is requested.

background

N/A

alternatives | other considerations

N/A

fiscal impact

N/A

**CITY OF WINTER PARK
COMMUNITY REDEVELOPMENT ADVISORY BOARD**

Regular Meeting
12:00 pm

August 23, 2018
Chapman Room

MINUTES

Chairman Javier Omana called the meeting to order at 12:00 p.m.

BOARD MEMBERS PRESENT: Javier Omana, Woody Woodall, Teri Gagliano, Alex Trauger, Jeff Stephens, Mike Emerson, and Lambrine Macejewski (arrived after approval of the minutes)

BOARD MEMBERS ABSENT:

STAFF MEMBERS PRESENT: Kyle Dudgeon, Lindsey Hayes, Laura Neudorffer

ADMINISTRATIVE ITEMS:

Item A: Approval of the 07-12-18 Meeting minutes

Motion made by Jeff Stephens, seconded by Javier Omana, to approve the July 12, 2018 minutes.

Motion passes 6-0.

ACTION ITEMS:

Item A: Downtown Bollard Pilot Program

Staff provided an update on the progress of the project. City will only be purchasing the bollards as City staff will be installing the bollards. Board requested bollards to be painted a reflective or bright color or to have a sleeve over them to make them as visible as possible to vehicles as well as pedestrians.

Motion made by Alex Trauger, seconded by Woody Woodall, to approve funding for the bollard program with the addition of reflective sleeves or caps to ensure visibility. Motion passes 7-0.

INFORMATIONAL ITEMS:

Item A: CRA Program Evaluation

Staff discussed the draft of the CRA Highlights flier and provided information on the updates made to the social programs managed by the CRA. Staff felt program outlines needed to be tightened up to provide better clarity to applicants. Board commented on whether ROI should be more detailed and inquired if the highlights would be posted on the City website once complete. Staff's goal was to provide a quick overview of the numbers to date rather than a complete summary of the programs.

Lawanda Thompson, 664 W.Lyman Ave., spoke on the desire and need for the CRA district to become more family oriented, increase affordable housing, and perhaps entice a charter school to open in the area so children of the community have walkability and more peers within their neighborhood. The goal would be to attract as well as maintain residents in the area. Board recommended she speak with City Commission to discuss the possibility of offering incentives that may bring Charter schools to the area.

Item B: Review of CRA Agency Meeting – July 23, 2018

Staff reviewed information relative to the CRA Agency meeting on July 23, 2018.

Agency agreed with the Board on the Winter in the Park alternative, street lighting, etc.

Staff requested that either the September or October Board meeting cover allocating funds for other CIP items as the only allocation made for 2019 at this point is 17-92 PD&E. Board also inquired if CRA AB would be able to review other Boards' priority lists to see if there are projects departments could work together on to complete.

NEW BUSINESS ITEMS:

Todd Weaver, 1051 Lake Bell Dr., spoke on the dry cleaner property located at Denning and Fairbanks. He stated busses have a very difficult time making the turn and often must stop traffic in order to do so. Busses have now begun using Pennsylvania Ave. Mr. Weaver suggested having Communications provide a schedule for the busses to assist traffic in the area. He also spoke on acquiring the post office property which he is a proponent of. He suggested rather than knocking down Progress Pointe, transform it into the new Post Office instead as it is a larger facility than where they are currently. He also suggested that the existing post office may be considered a historical monument and if purchased by the City perhaps it could be used as a historical site, and/or possibly expand on the Farmer's Market footprint.

ADJOURNMENT:

Next meeting scheduled for September 27, 2018 at 12:00 p.m.

There being no further business to discuss, the meeting adjourned at p.m.

Chairman, Javier Omana

Board Liaison, Laura Neudorffer

winter park

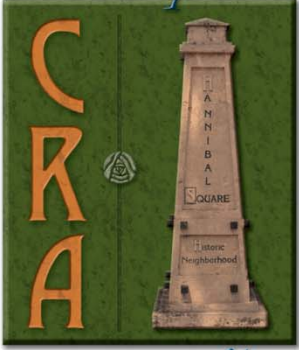

community
redevelopment
agency

agenda item

meeting date	November 1, 2018	approved by <input type="checkbox"/> City Manager <input type="checkbox"/> City Attorney <input checked="" type="checkbox"/> N/A
item type	<input checked="" type="checkbox"/> Administrative <input type="checkbox"/> Action <input type="checkbox"/> Information	

advisory board

Subject 1b

Discussion with new Community Development Director

motion | recommendation

N/A

background

Staff is providing an introduction to the new Community Development Director that will be interacting with the board moving forward.

alternatives | other considerations

N/A

fiscal impact

N/A

winter park

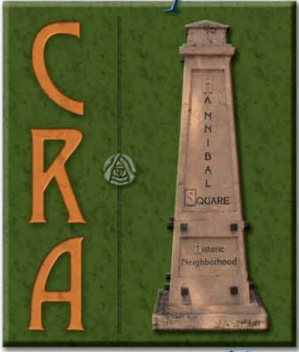

community
redevelopment
agency

agenda item

meeting date	November 1, 2018	approved by <input type="checkbox"/> City Manager <input type="checkbox"/> City Attorney <input checked="" type="checkbox"/> N/A
item type	<input type="checkbox"/> Administrative <input type="checkbox"/> Action <input checked="" type="checkbox"/> Information	

advisory board

Subject 3a

Hannibal Square Streetscape Guidelines

motion | recommendation

N/A

background

CRA has been working with planning staff on the development of streetscape guidelines for the Hannibal Square area. The origin of these guidelines lay, in part, to the potential evaluation of providing additional opportunity within city right-of-way for shade and understory trees. This is in addition to providing further direction on streetscape improvements as CRA/city projects, development, and redevelopment occurs. Coordination on this project includes input from several city departments including:

Public Works: Each street type provides varying space within the right of way. Each takes into consideration appropriate placement of bulb-outs and curb cuts that would be coordinated with the city's public works team. Final costs for moving the curb have not been calculated at this time. Coordination with other projects in the area may help determine the level of focus required by the CRA.

Two additional considerations to be evaluated include parking and stormwater. Potential changes in parking behavior where curb cuts and bulb-outs would be located is likely a result of these guidelines. Staff will also be coordinating with the public works team on potential stormwater impacts, if any.

Electric Utility: The placement of street furniture, planter areas, and trees would need to be coordinated with electric utility to avoid the current placement of transformer boxes in the area.

In addition, the utility is in the area performing undergrounding services in concert with the residential decorative lighting and tree program provided by the CRA.

Urban Forestry: Coordination on tree species and landscape installation would be handled in cooperation with Urban Forestry.

No action is required by the board at this time as this is an informational item set on receiving feedback on the concept and its intent. Next steps for staff include receiving feedback by the board and developing the concept to understand potential implications.

alternatives | other considerations

At the pleasure of the board

fiscal impact

N/A

HANNIBAL SQUARE DISTRICT

[STREETSCAPE DESIGN GUIDELINES]

CITY OF WINTER PARK



MISSION

“ESTABLISH A STREET
TREE AND STREETScape
IMPLEMENTATION PLAN
FOR HANNIBAL SQUARE”

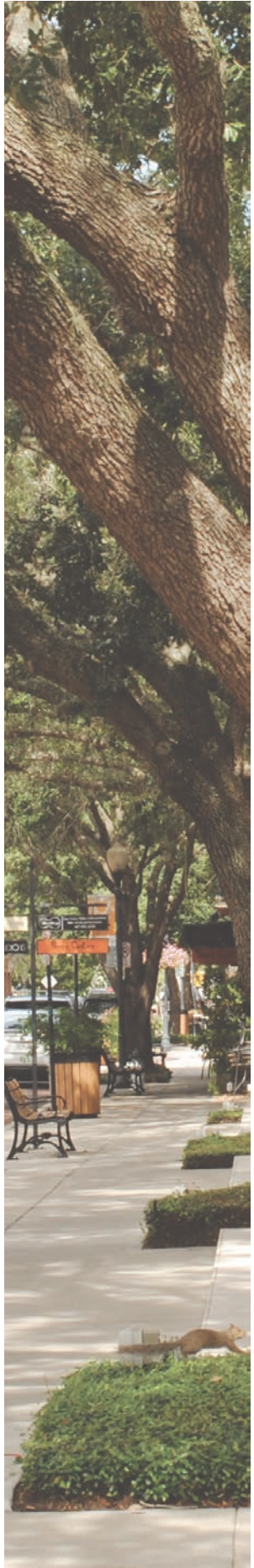
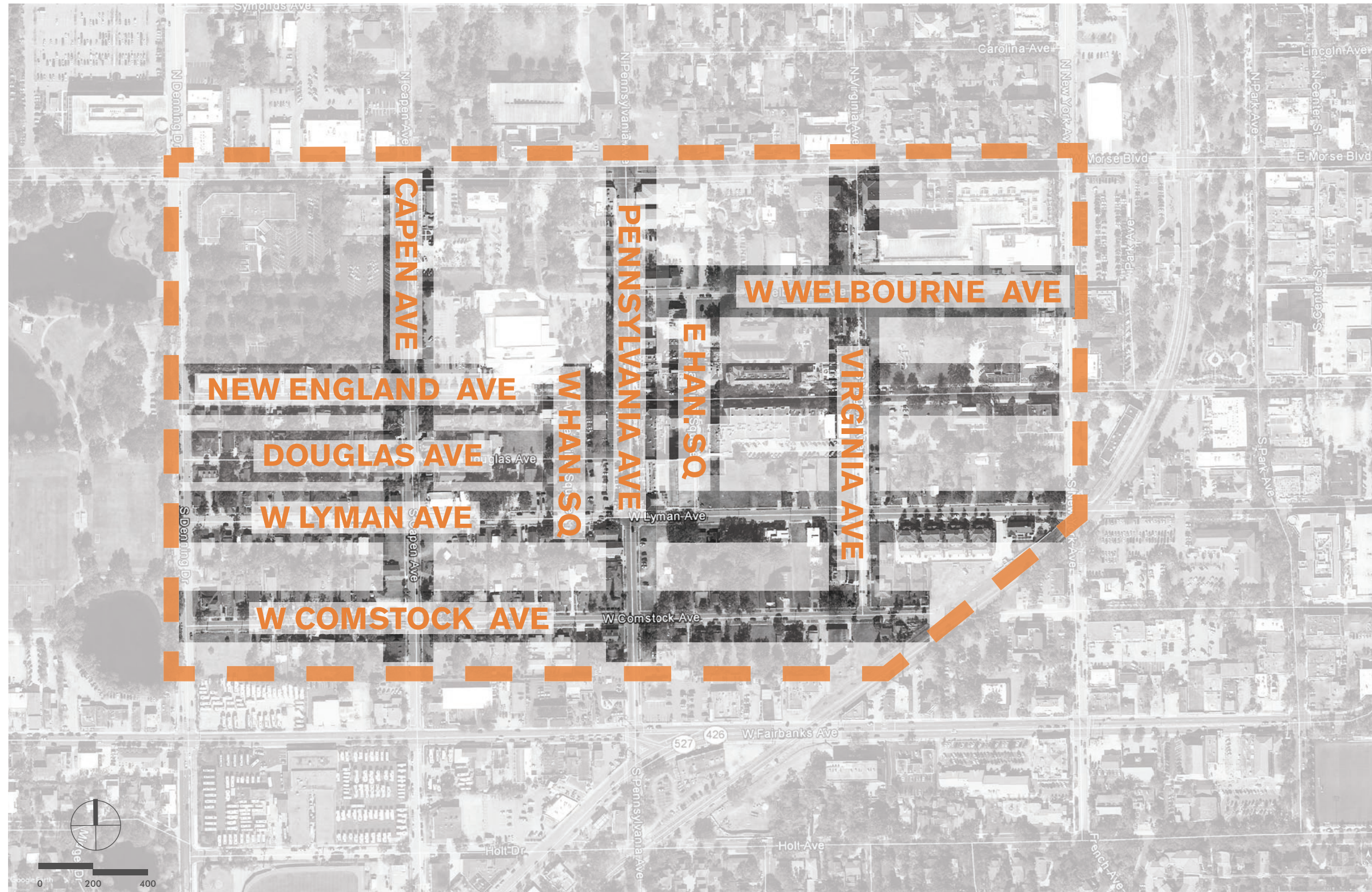

TABLE OF CONTENTS

KEY MAP	4
TYPE A	6
TYPE B	8
TYPE C	10
TYPE D	11
TYPE E	12
TYPE F	14

HANNIBAL SQUARE DISTRICT STUDY AREA



STREET TYPES



ROAD TYPES KEY

- TYPE A
- TYPE B
- TYPE C
- TYPE D
- TYPE E
- TYPE F
- TYPE G (EXISTING)

DESIGN PROPOSAL

[TYPE 'A']

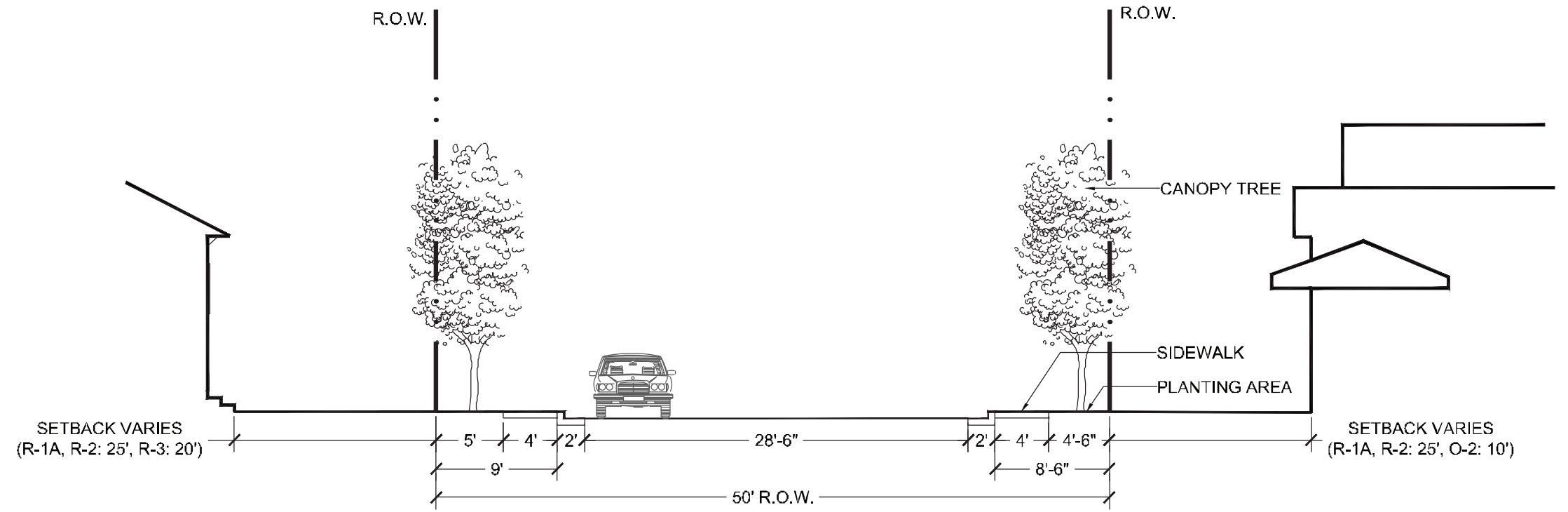
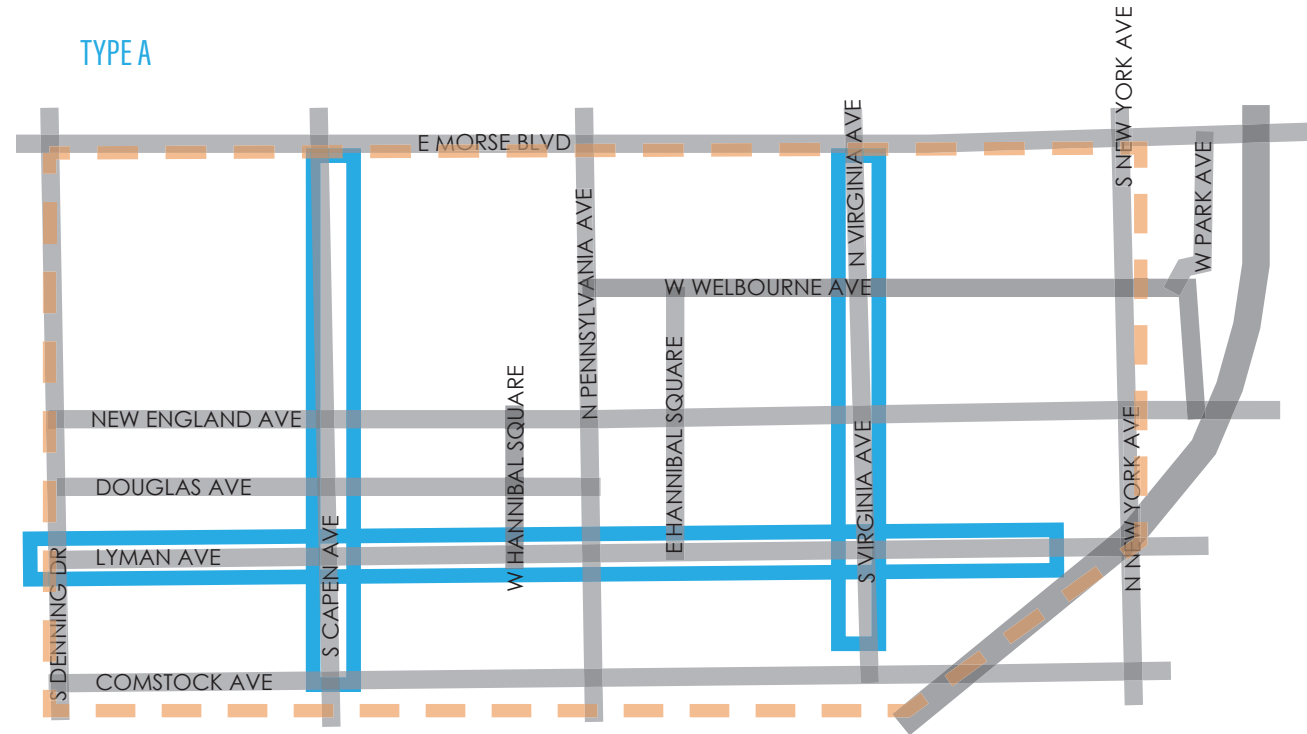

*ALL DIMENSIONS ARE APPROXIMATE

SCALE: 1"=10'



TYPE A

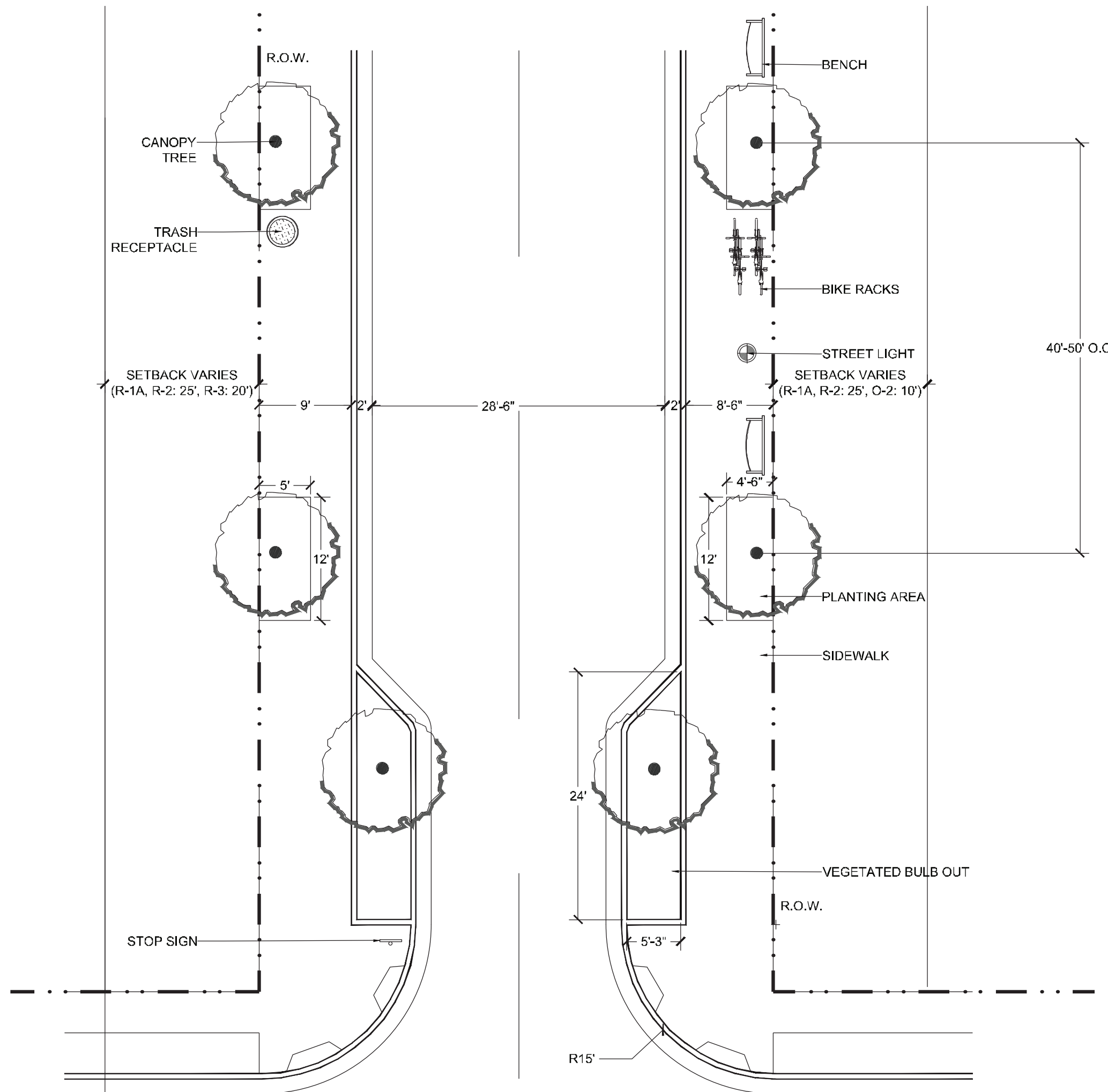

*ALL DIMENSIONS ARE APPROXIMATE

SCALE: 1"=10'



DESIGN PROPOSAL

[TYPE 'B']

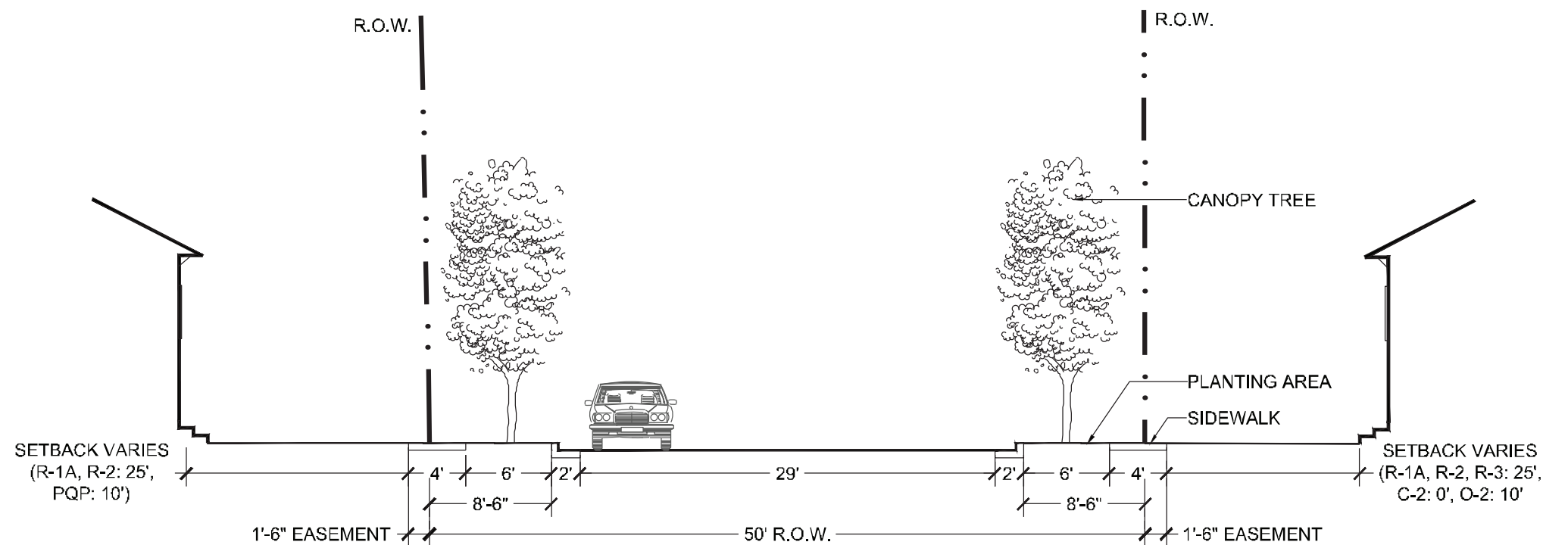

*ALL DIMENSIONS ARE APPROXIMATE

SCALE: 1"=10'



TYPE B

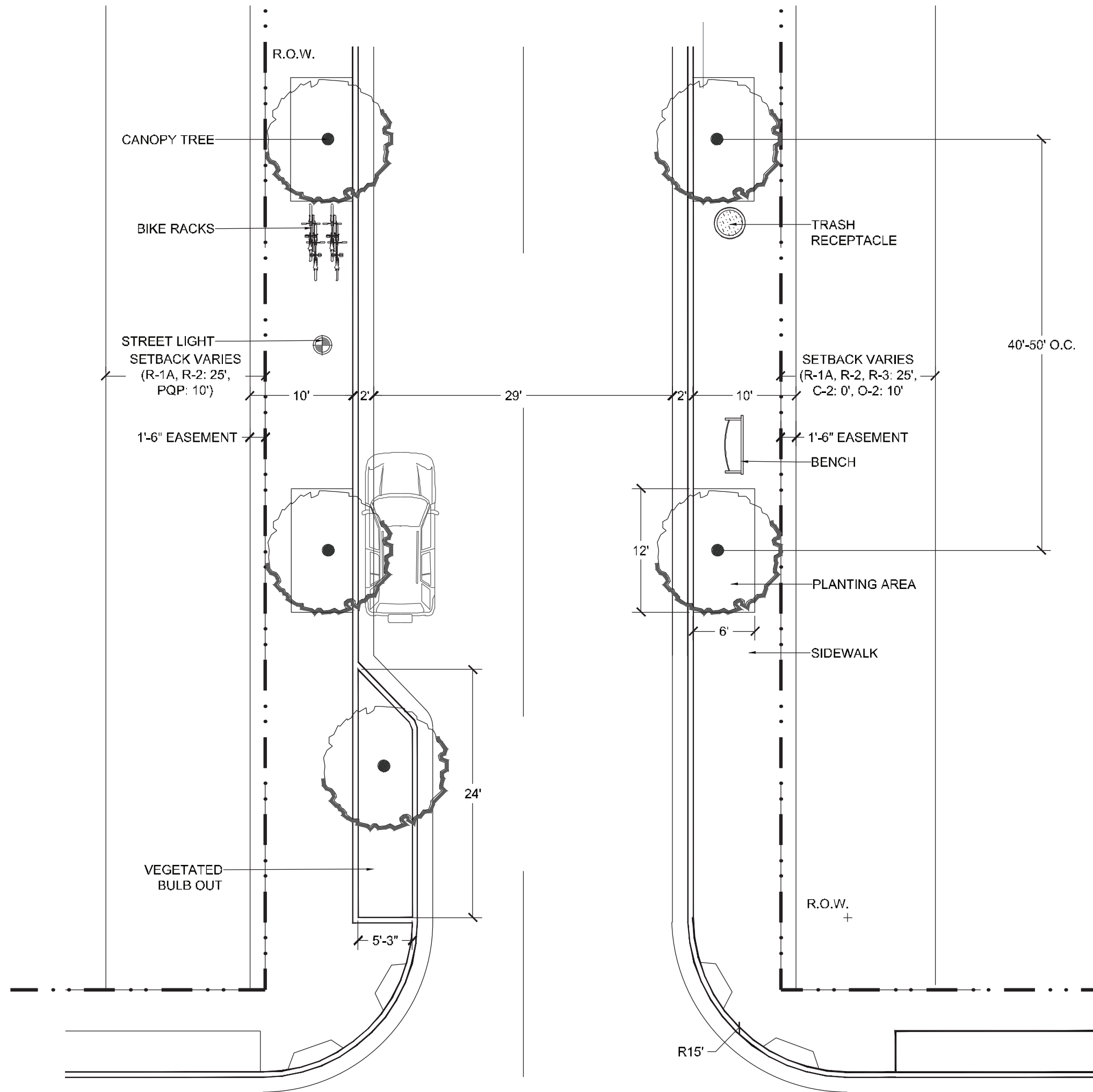

*ALL DIMENSIONS ARE APPROXIMATE

SCALE: 1"=10'



DESIGN PROPOSAL

[SECTION 'C']

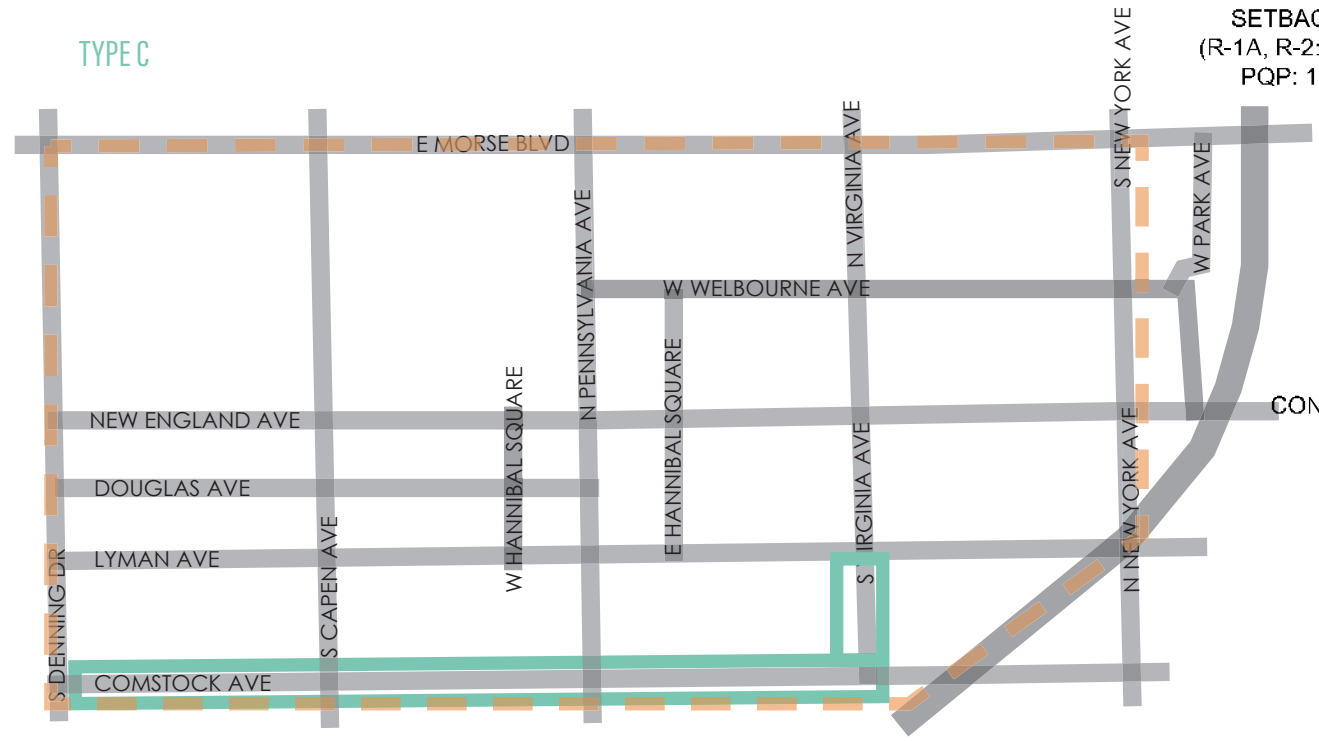

SETBACK VARIES
(R-1A, R-2: 25', O-2, C-3,
PQP: 10', C-2: 0')

SETBACK VARIES
(R-1A: 25', C-3, O-2: 10',
C-2: 0')

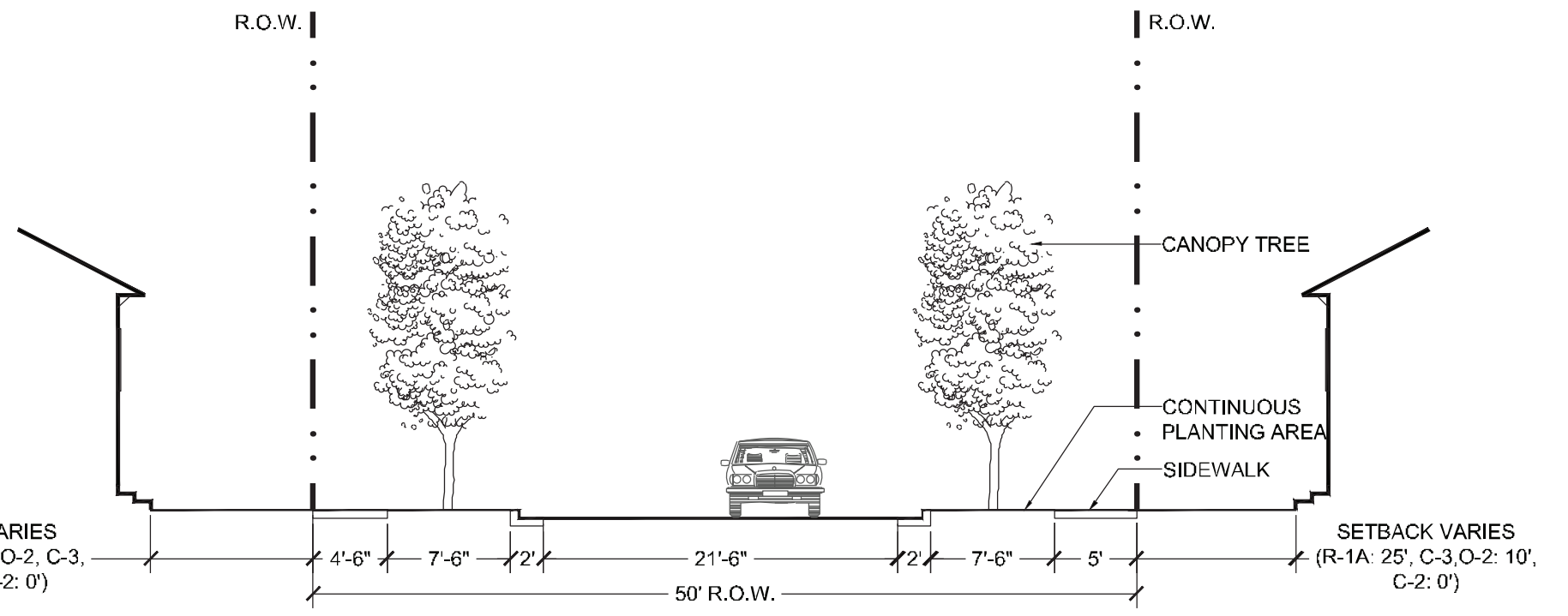
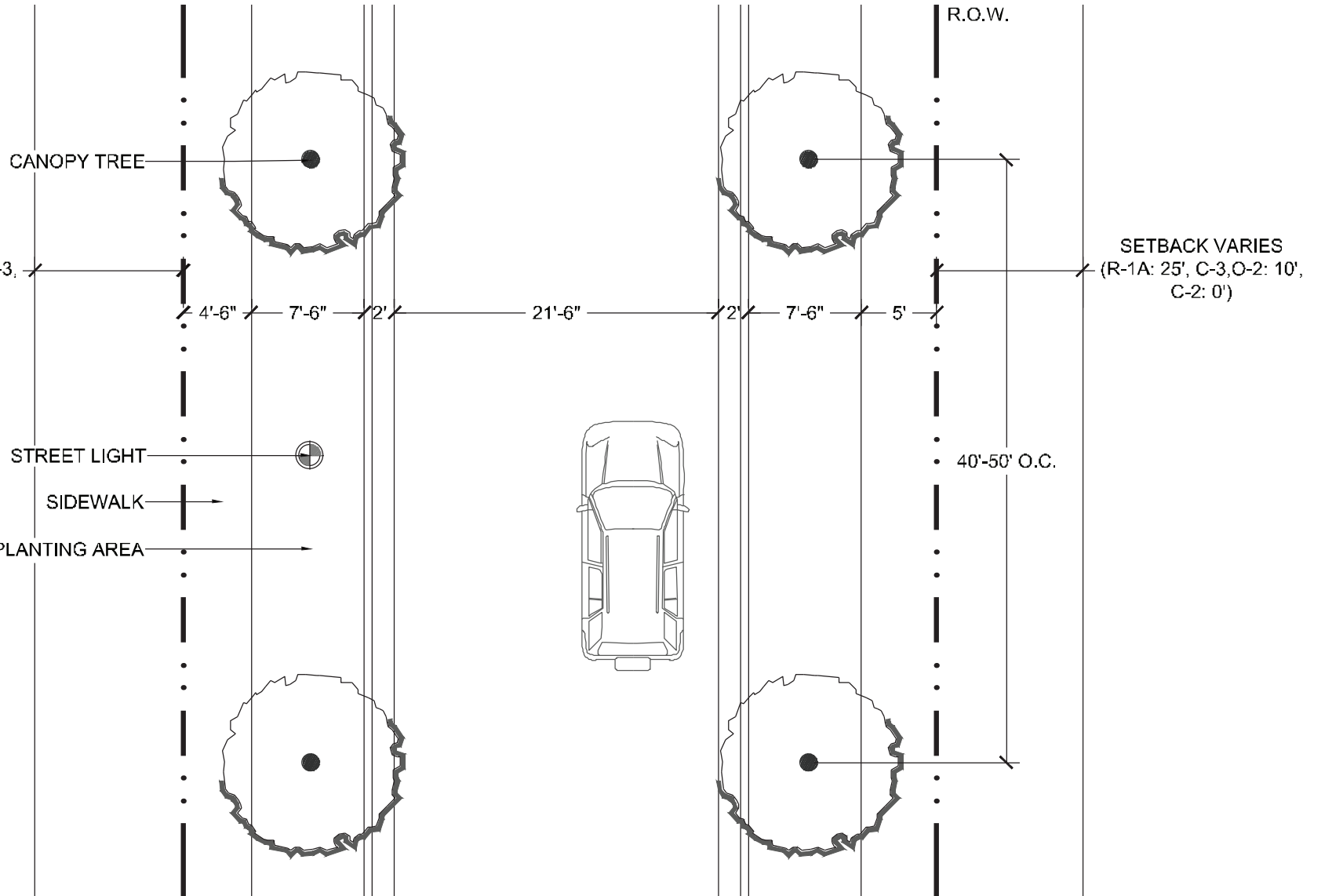

*ALL DIMENSIONS ARE APPROXIMATE

SCALE: 1"=10'



DESIGN PROPOSAL

[SECTION 'D']

TYPE D



SETBACK VARIES
(R-2: 25', C-3, PQP: 10', C2: 0')

CONTINUOUS PLANTING AREA

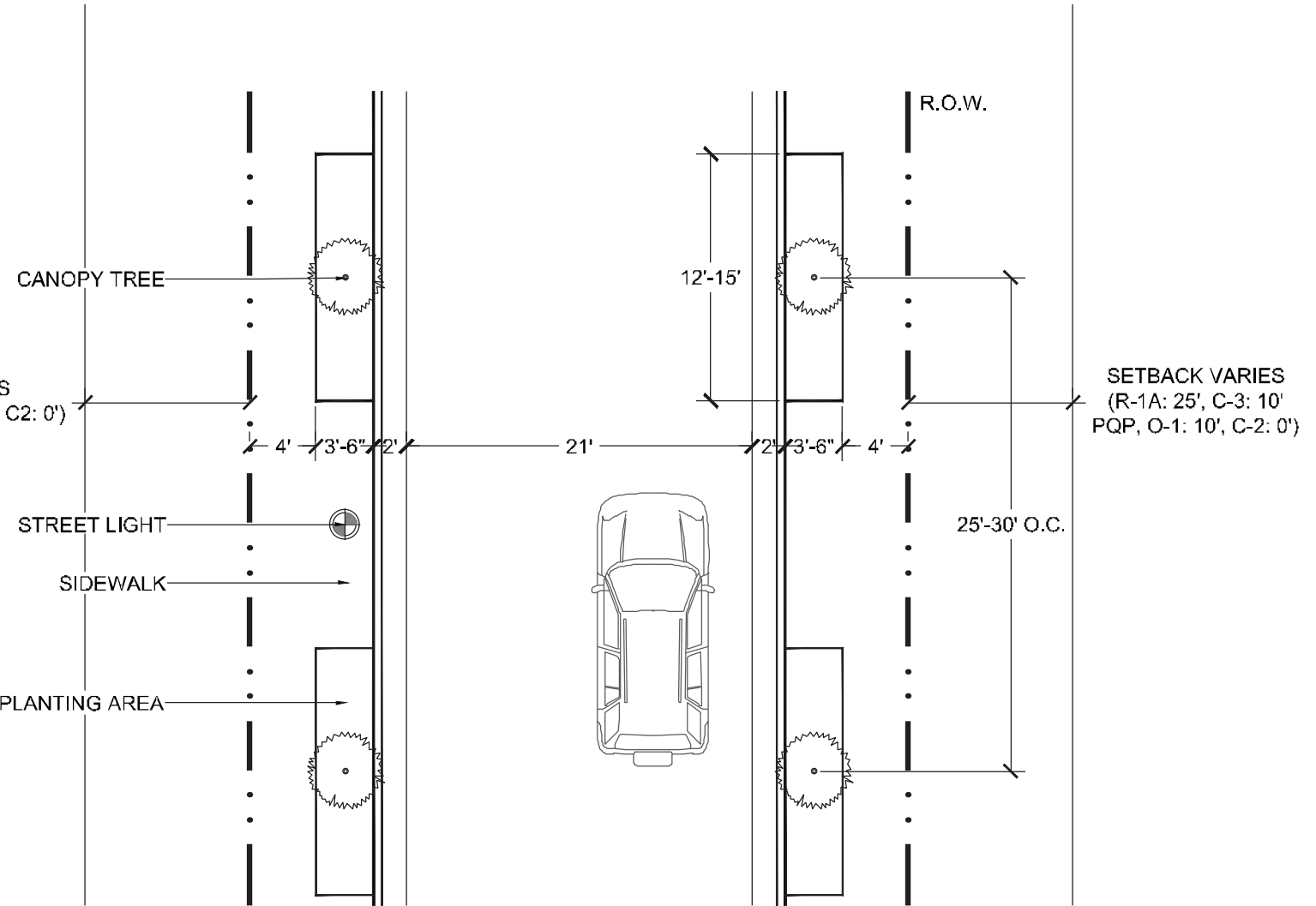

SETBACK VARIES
(R-1A: 25', C-3: 10'
PQP, O-1: 10', C-2: 0')

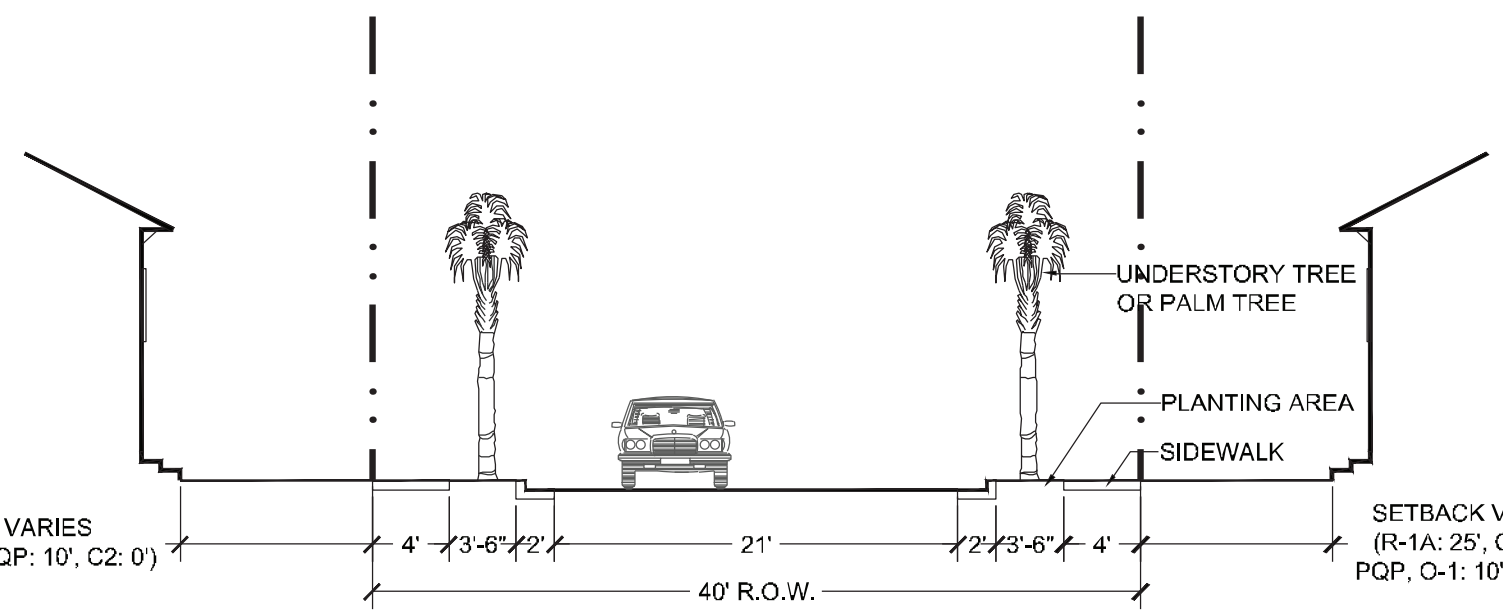

SETBACK VARIES
(R-2: 25', C-3, PQP: 10', C2: 0')

SETBACK VARIES
(R-1A: 25', C-3: 10'
PQP, O-1: 10', C-2: 0')

*ALL DIMENSIONS ARE APPROXIMATE

SCALE: 1"=10'



DESIGN PROPOSAL

[SECTION 'E']

TYPE E

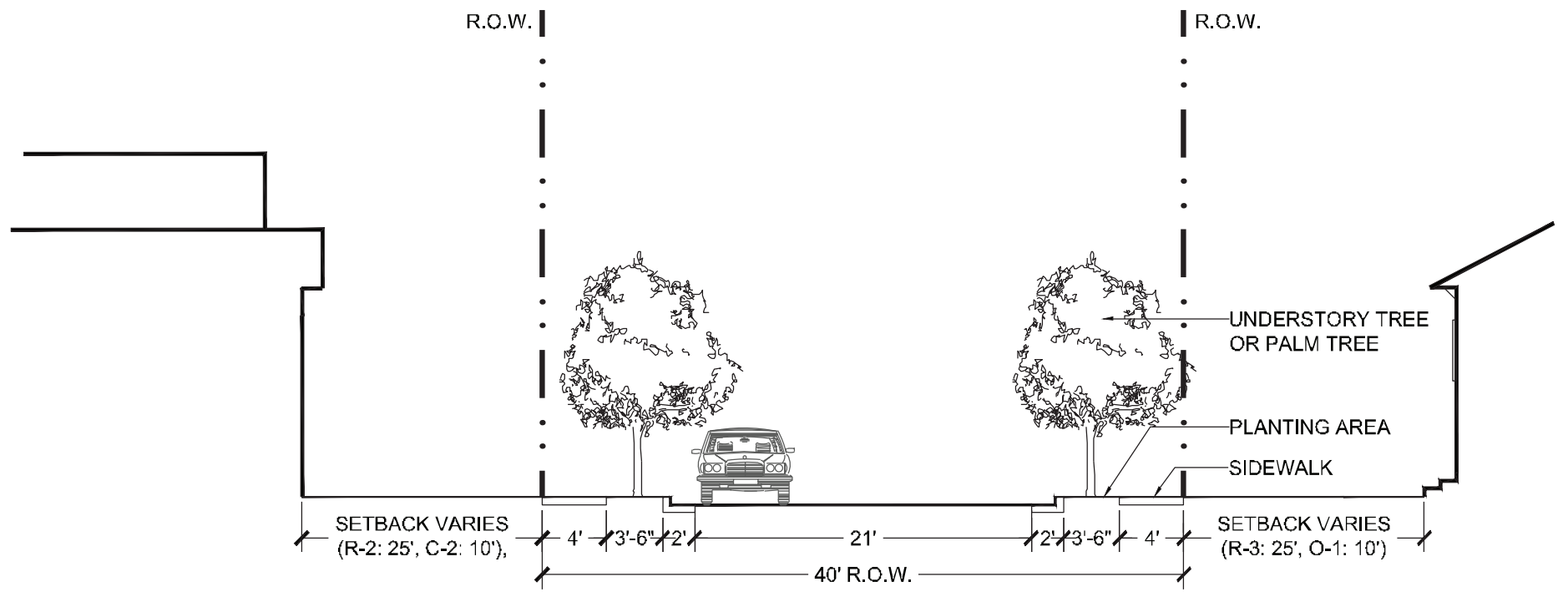
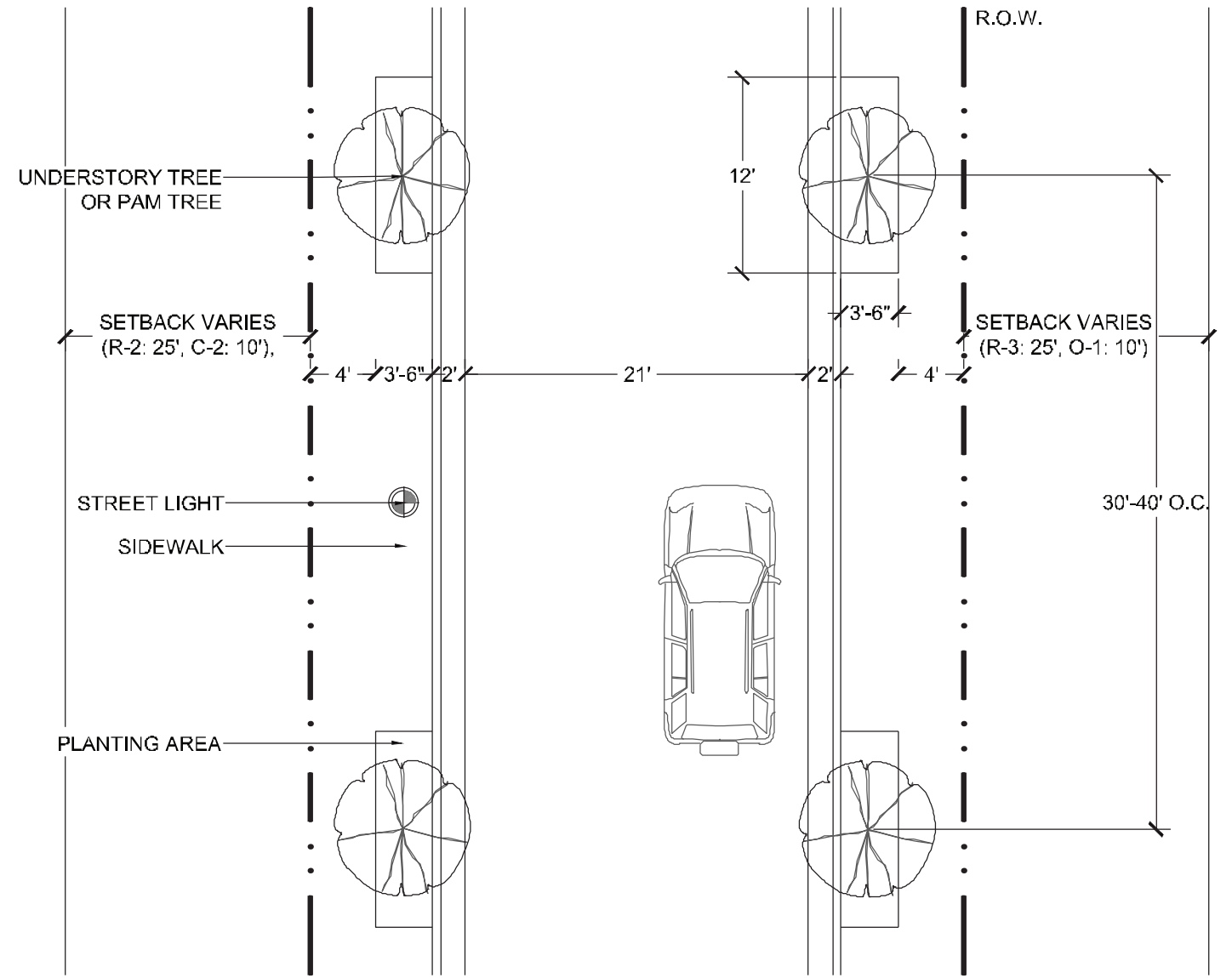
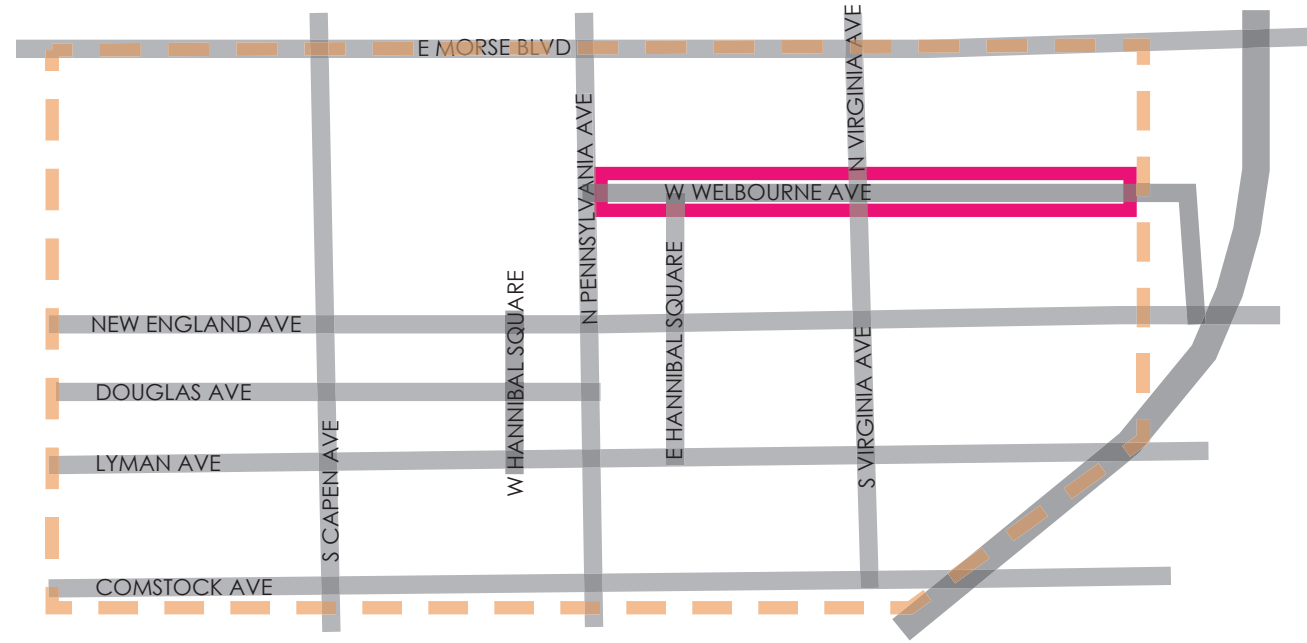

*ALL DIMENSIONS ARE APPROXIMATE

SCALE: 1"=10'



DESIGN PROPOSAL

[SECTION 'E' ALTERNATIVE]

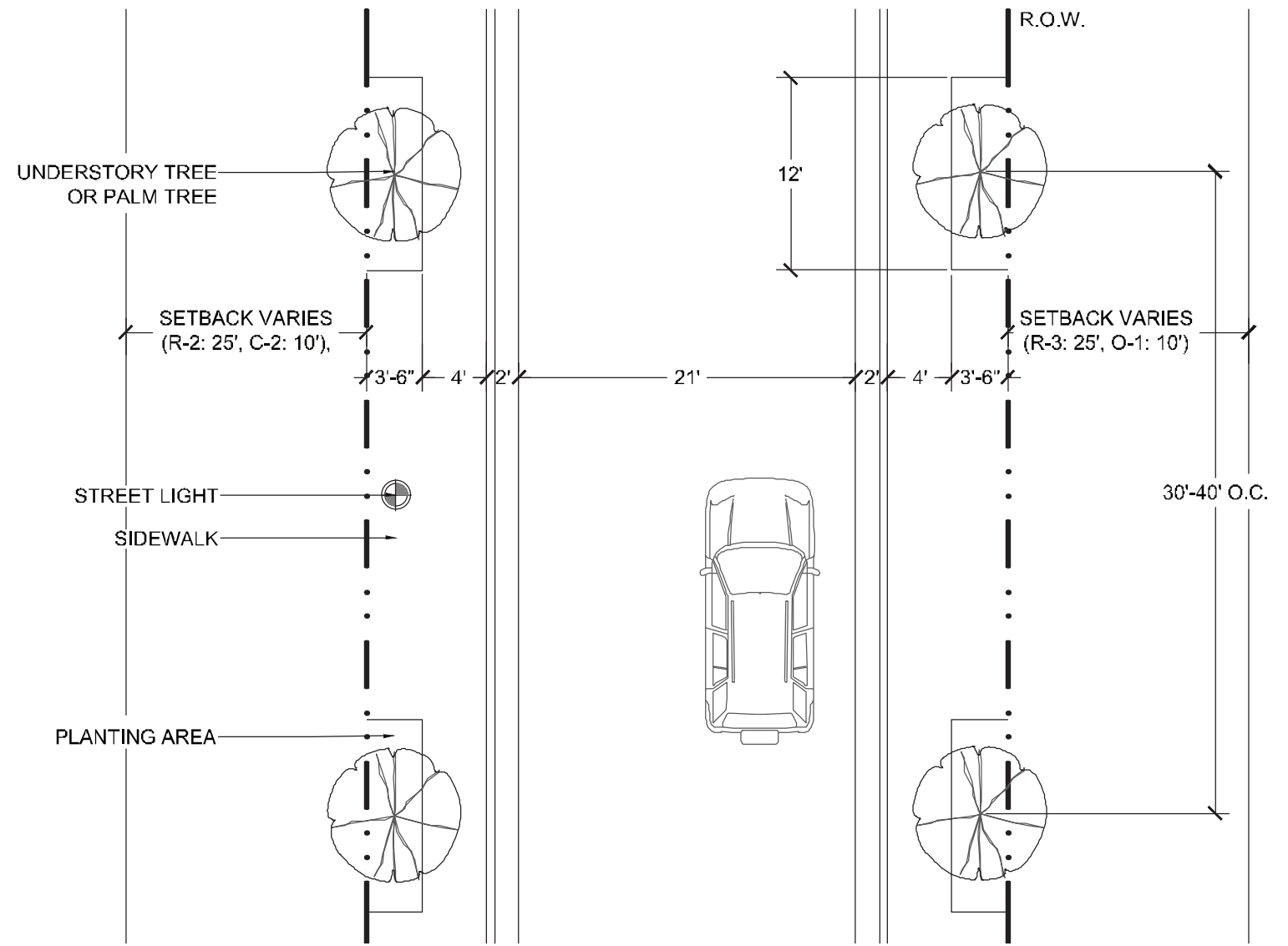
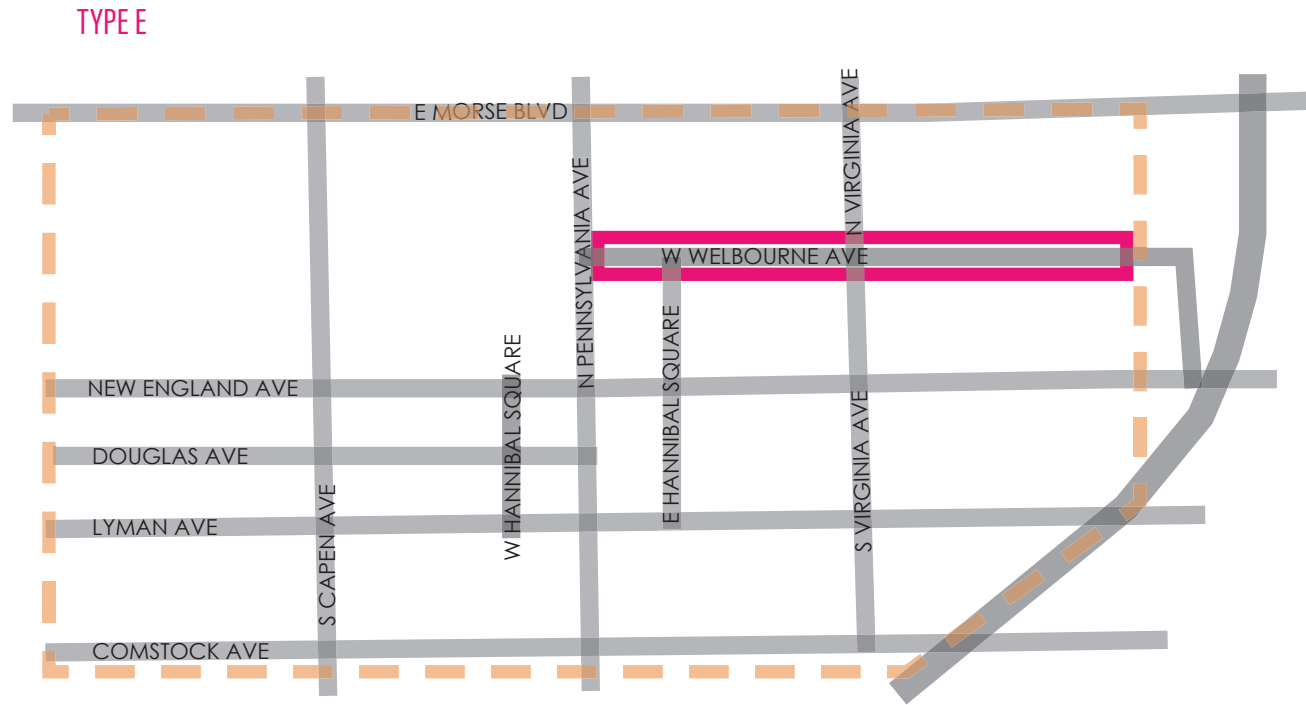

*ALL DIMENSIONS ARE APPROXIMATE
 SCALE: 1"=10'
 0 5 10'

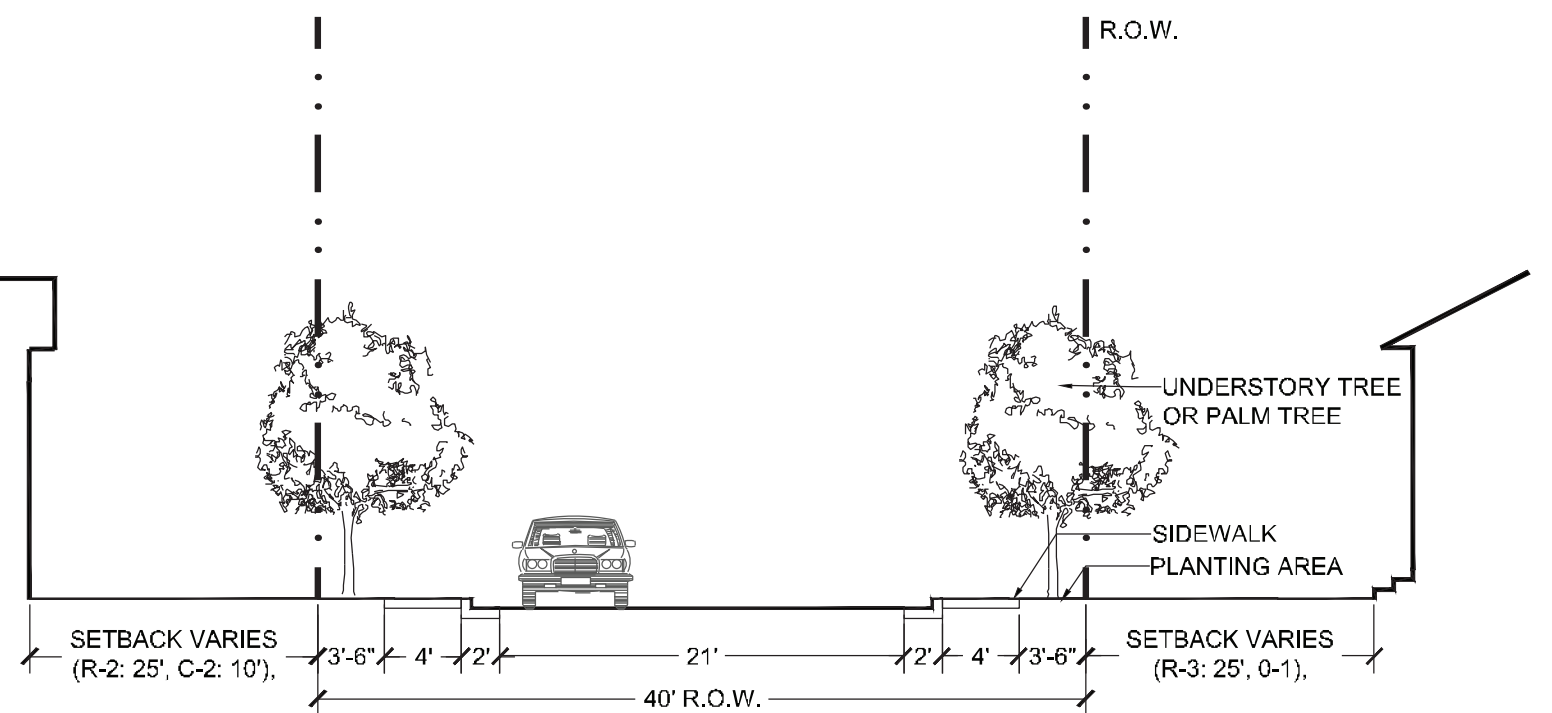

DESIGN PROPOSAL

[SECTION 'F']

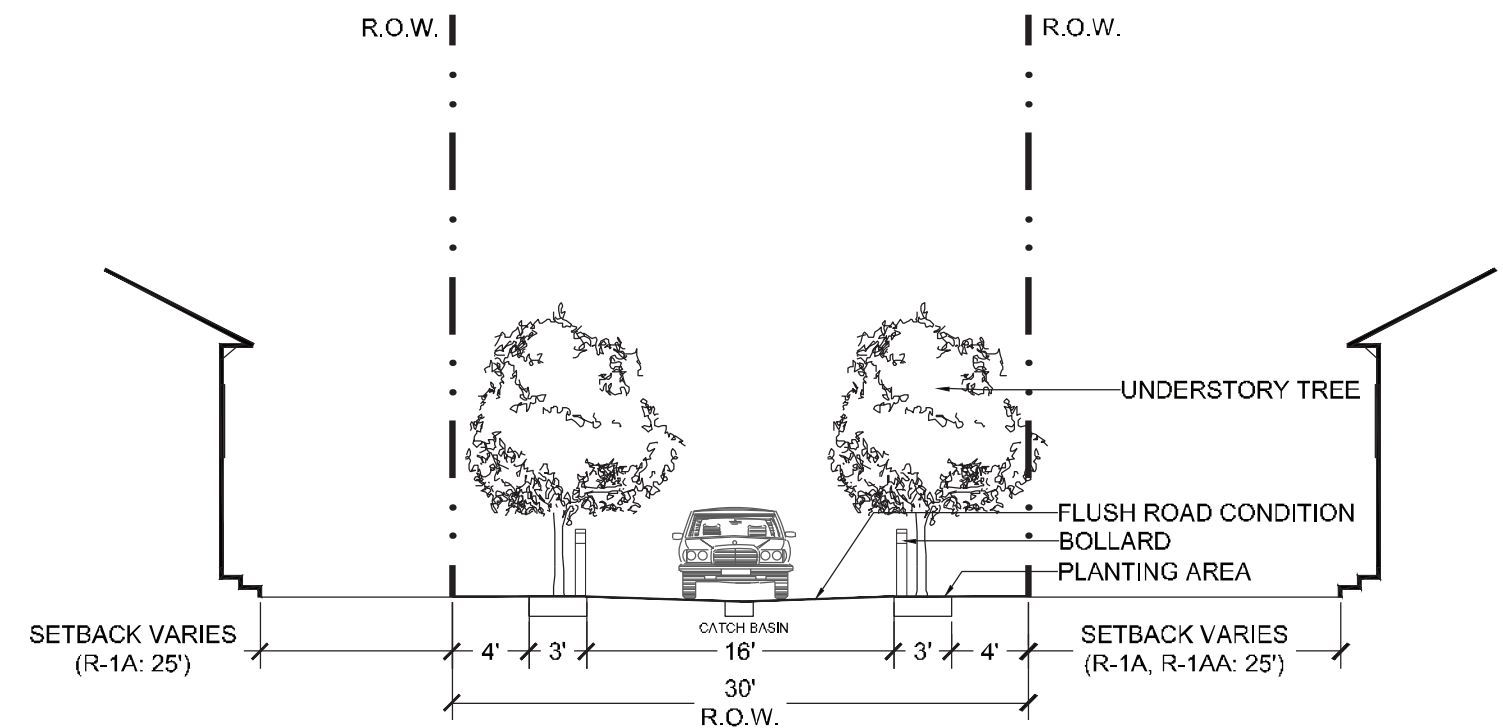
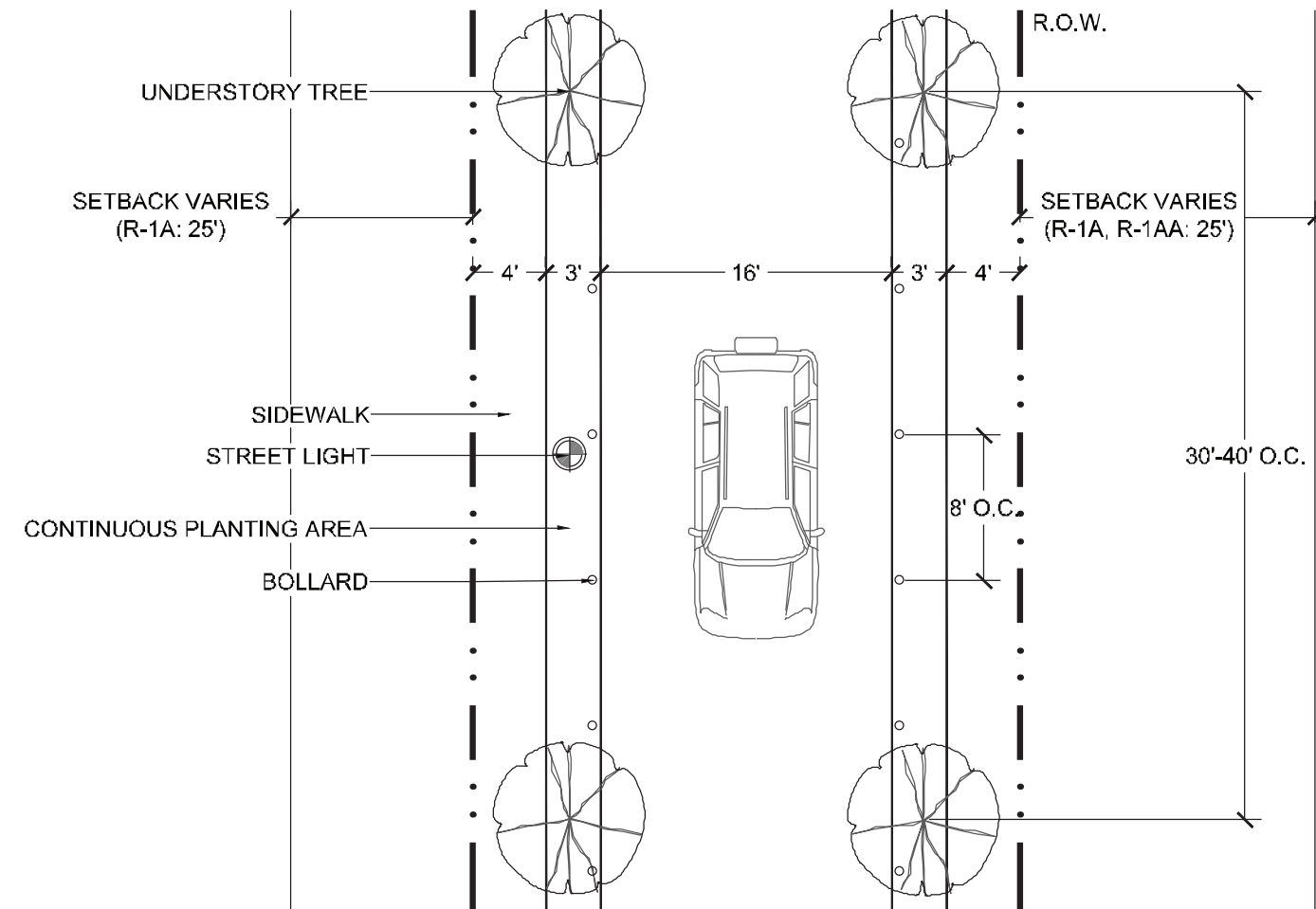
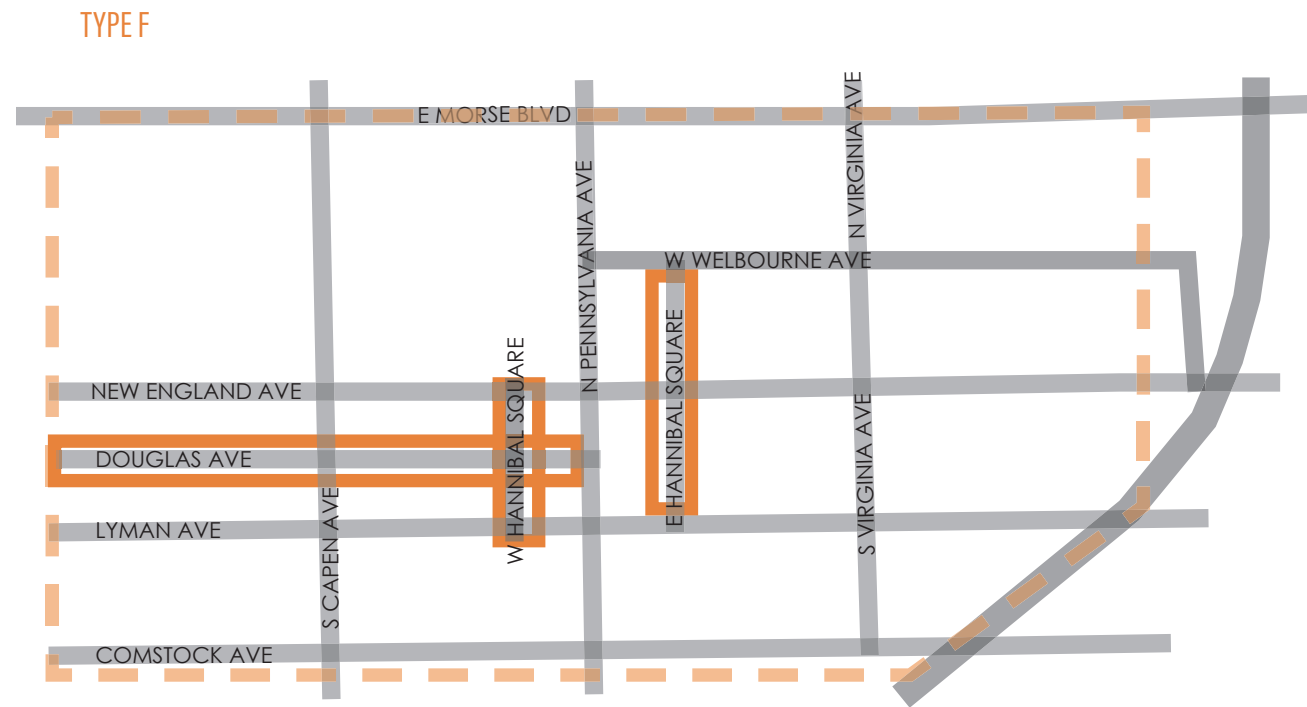

*ALL DIMENSIONS ARE APPROXIMATE

SCALE: 1"=10'



HANNIBAL SQUARE DISTRICT



winter park

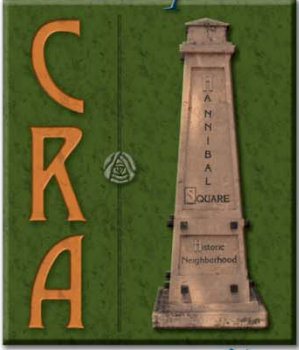

community
redevelopment
agency

agenda item

meeting date	November 1, 2018	approved by <input type="checkbox"/> City Manager <input type="checkbox"/> City Attorney <input checked="" type="checkbox"/> N/A
item type	<input type="checkbox"/> Administrative <input type="checkbox"/> Action <input checked="" type="checkbox"/> Information	

advisory board

Subject 3b

Snow in the Park special event

motion | recommendation

N/A

background

Staff has requested the presence of Parks and Recreation staff to provide an update to the board on the new Winter special event "Snow in the Park" provided by the CRA as part of the FY18-19 budget.

alternatives | other considerations

N/A

fiscal impact

winter park

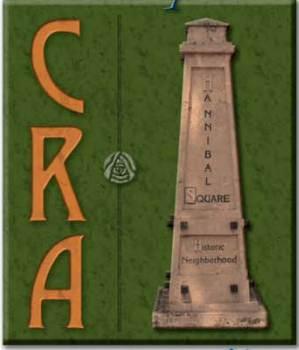

community
redevelopment
agency

agenda item

meeting date	November 1, 2018	approved by <input type="checkbox"/> City Manager <input type="checkbox"/> City Attorney <input checked="" type="checkbox"/> N/A
item type	<input type="checkbox"/> Administrative <input type="checkbox"/> Action <input checked="" type="checkbox"/> Information	

advisory board

Subject 4a

FRA Conference/Denning Drive

motion | recommendation

N/A

background

Staff is providing a short video produced by Full Sail University on the development of Denning Drive that was presented to the Florida Redevelopment Association (FRA) conference on October 24th, 2018.

alternatives | other considerations

N/A

fiscal impact

\$0

winter park

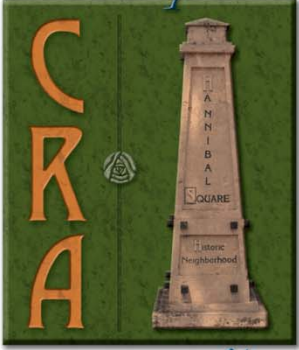

community
redevelopment
agency

agenda item

meeting date	November 1, 2018	approved by <input type="checkbox"/> City Manager <input type="checkbox"/> City Attorney <input checked="" type="checkbox"/> N/A
item type	<input type="checkbox"/> Administrative <input type="checkbox"/> Action <input checked="" type="checkbox"/> Information	

advisory board

subject

Next CRAAB meeting date

motion | recommendation

N/A

background

The next regularly scheduled CRAAB meeting is November 22, 2018. Due to the holiday, staff is requesting board consideration of an alternative date as well as discussion on board availability for a December meeting currently scheduled for the 27th.

alternatives | other considerations

- Provide alternative dates
- Combine meeting
- Cancel meeting

fiscal impact

N/A